

**General Specifications:**

- Vessel Design per A.S.M.E. Boiler & Pressure Vessel Code, Section VIII, Div I. (Not Code Stamped)
- Lifting Certified per NUREG-0612
- Designed to be Sluiced In/Out while Submerged in Pool.
- All Material: 304L Stainless Steel
- Resin Capacity: 50 Cu. Ft.
- Power Requirements: 5HP, 460V, 3 PH, 60 Hz, 9.9A
- Design Flow Rate: 200 GPM
- Design Pressure: 50 PSIG
- Vessel Empty/Dry with Pump: 1,275 lbs.
- Vessel Full of Resin/Water with Pump: 5,750 lbs.



**Tri Nuclear Corp.**  
 P.O. Box 1130, Ballston Lake, NY 12019

**Underwater Demineralizer**  
**48" OD, 200 GPM, 50 CU. FT. Capacity**

Model No. UD-48A	Rev. Date Rick Russell 08/25/17	Brochure	
Dwg. TNC-013-02	Apv'd Date James L. Warden 08/30/17	Rev. C	Page 1 of 3

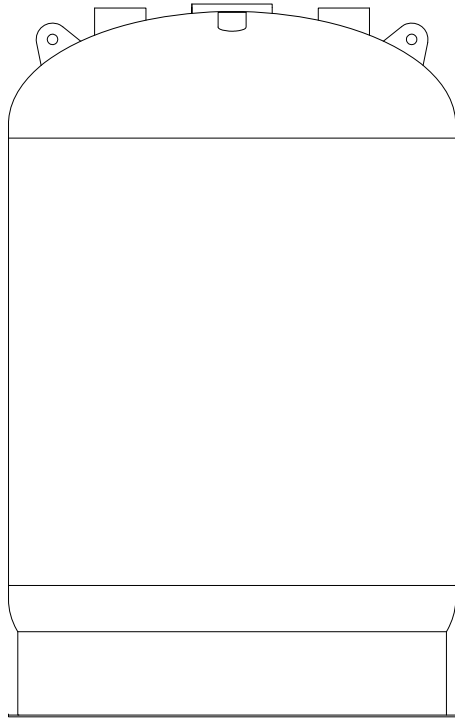

UD-48A-Inlet Inlet Screen  
Qty: 2



UD-48A-V Vessel

UD-48A-V Vessel

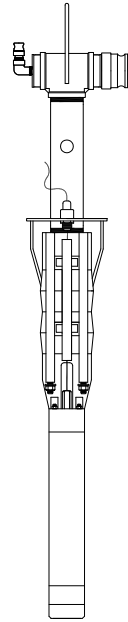

PP-260SC Pump

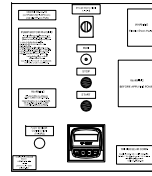

CB-260-FM  
Phase Reversing Control Box  
with Integral Flow Meter

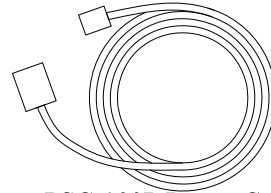

PSC-100P Power Cord  
with Twistlock Plug

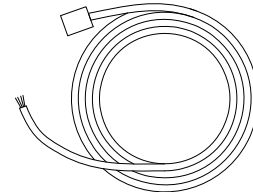

PC-50 Drop Cable  
with Twistlock Plug

PP-260SC Pump

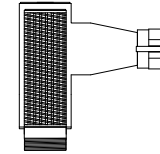

SHCK-SSVA-3x4  
Safety Screen Vent Assembly  
Qty: 2

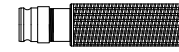

SHCK-JS-4x12  
Johnson Screen Strainer  
Qty: 2

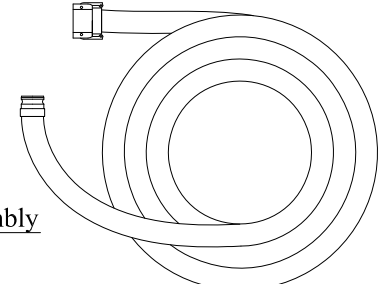

PH-3x50 Suction Hose  
Qty: 2

SHCK-UD-48A Suction Hose Conversion Kit



FM-SRD Flow Sensor

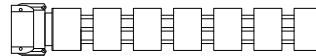

UT-8 3" Diffuser Pipe

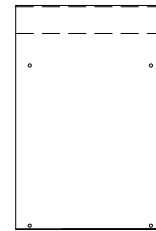

UT-10C Mounting Panel

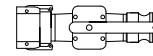

BV-1.5SS-MxF  
Sluice Isolation Valve  
Qty: 2

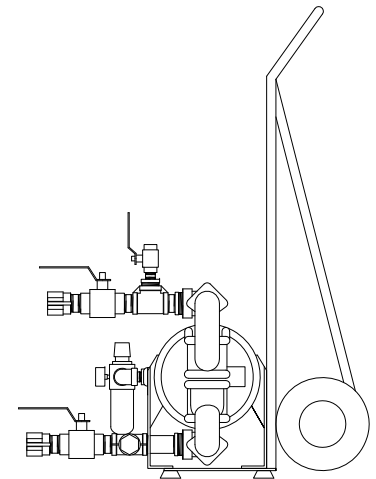

AP-65 Sluice Pump

NOTE: Not supplied with system.

**NOTE:**

*All Items Shown come with the UD-48A in listed quantity except as noted.*

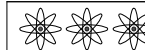

**Tri Nuclear Corp.**

P.O. Box 1130, Ballston Lake, NY 12019



**UD-48A System**  
**Part Identification**

Model No. **UD-48A**

Dwg. **TNC-013-02**

Rev. **C**

Page 2 of 3

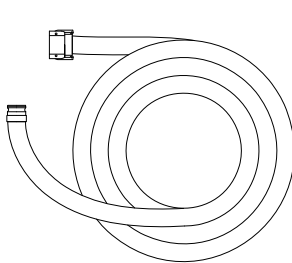

FPS-1.5x50 Sluice Hose  
Qty: 2

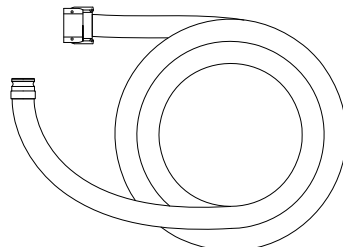

PH-3x25 Discharge Hose

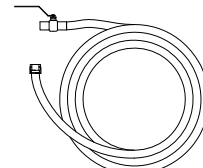

SH-.5x100 Sample Hose

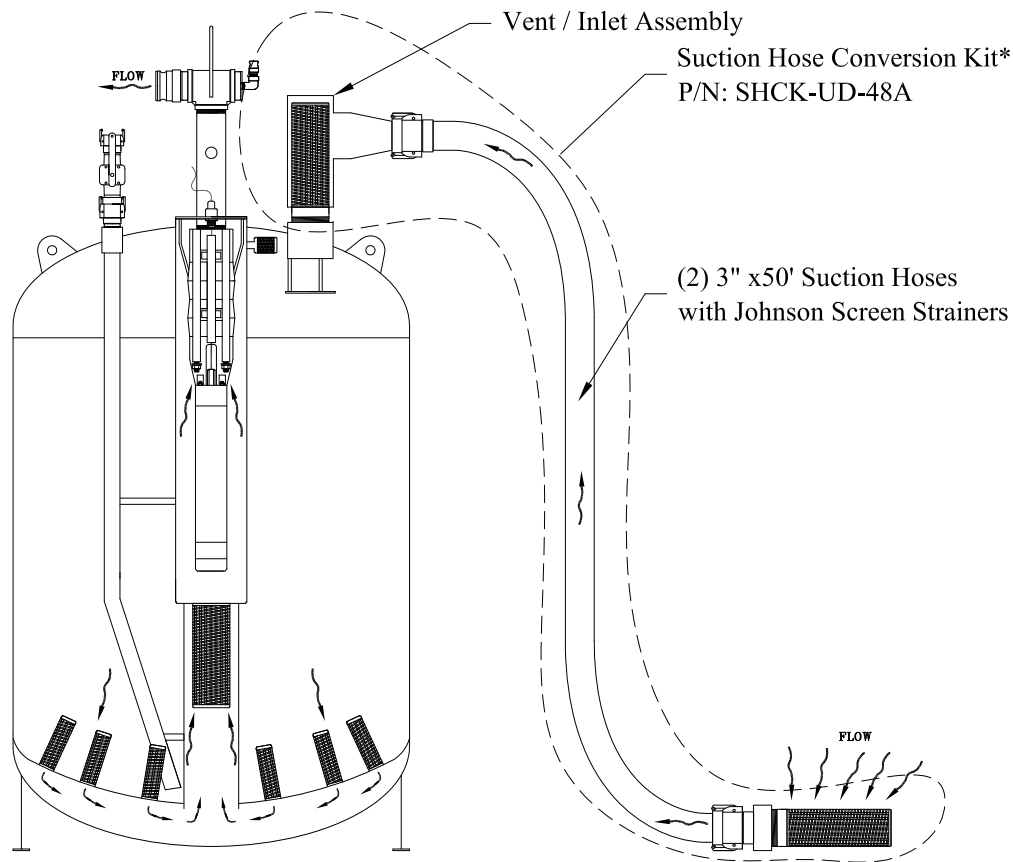

**"OPTIONAL"  
SUCTION HOSE OPERATIONS**

Dual Suction Hoses attached to Vessel Inlet. No Hose attached to discharge of pump.

**\*SHCK-UD-48A Includes:**

- (2) Safety Screen Vent Assembly, P/N: SHCK-SSVA-3x4
- (2) Suction Hose, P/N: PH-3x50
- (2) Johnson Screen Strainer, P/N: SHCK-JS-4x12

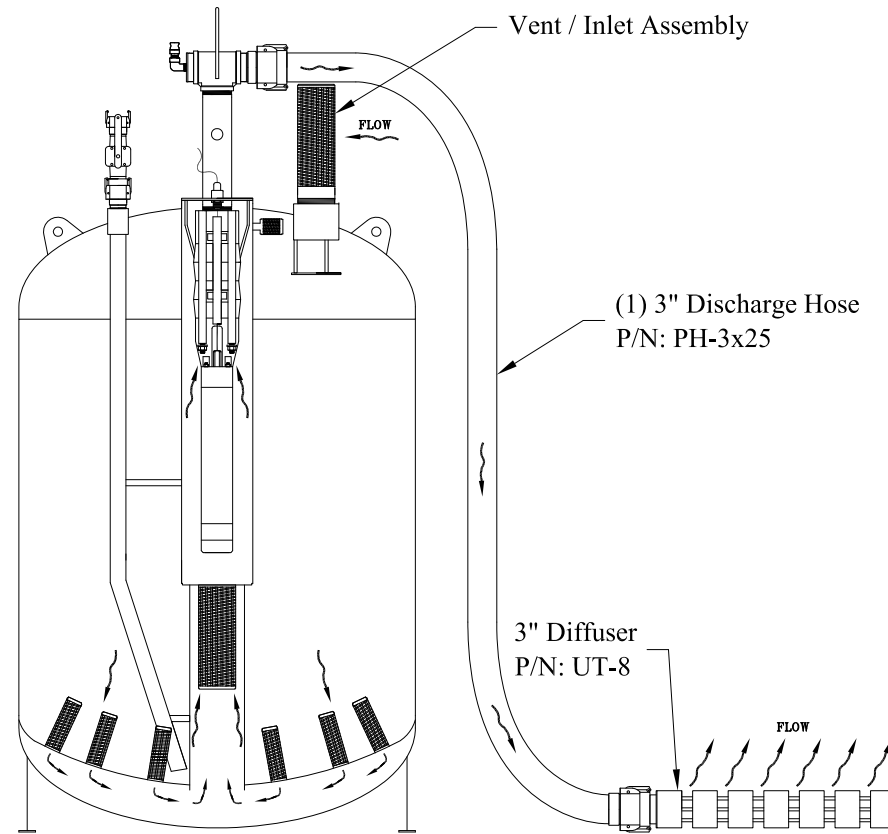

**"TYPICAL"  
DISCHARGE HOSE OPERATIONS**

NOTE: UD-48A to be run with either Suction or Discharge Hoses attached for efficient cross-circulation. This system is not required to run with both Suction & Discharge Hoses.

**Tri Nuclear Corp.**  
 P.O. Box 1130, Ballston Lake, NY 12019
 

**UD-48A System  
Modes of Operation**

Model No.	UD-48A	Dwg.	TNC-013-02	Rev.	C	Page	3 of 3
-----------	--------	------	------------	------	---	------	--------